

Classic (6LR61)

9V

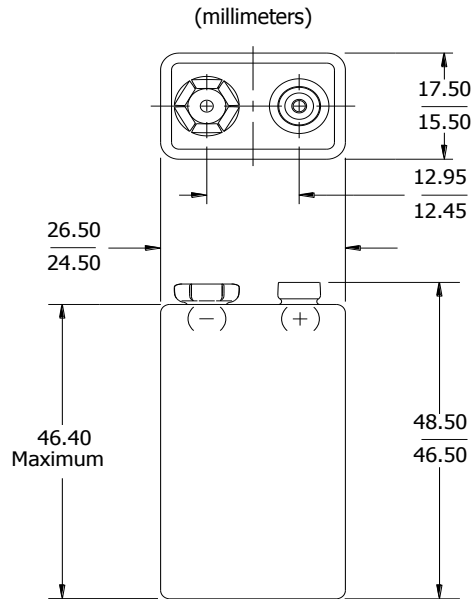

Industry Standard Dimensions



Specifications



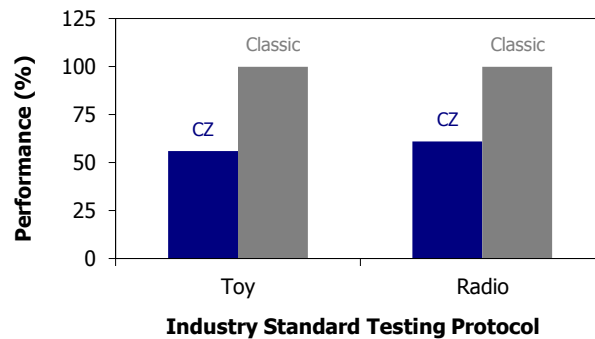

Classification:	Alkaline
Chemical System:	Zinc-Manganese Dioxide (Zn/MnO ₂) No added mercury or cadmium
Designation:	IEC-6LR61
Nominal Voltage:	9.0 volts
Operating Temp:	-18°C to 55°C
Typical Weight:	46.0 grams
Typical Volume:	21.0 cubic centimeters
Jacket:	Metal
Shelf Life:	5 years at 21°C
Terminal:	Miniature Snap

Performance Comparison

Classic vs. Typical Carbon Zinc (9V) at 21°C



Device Selection Guide:

- Toy 
- Baby Monitor 
- Garage Opener 
- Clock Radio 
- Smoke Detector 

Battery Selection Indicator

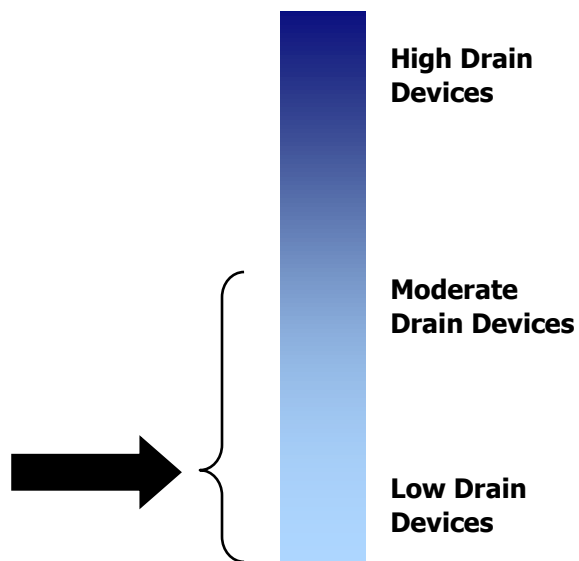

Important Notice

This datasheet contains typical information specific to products manufactured at the time of its publication.
©Energizer Holdings, Inc. - Contents herein do not constitute a warranty.