

Classic (LR20)

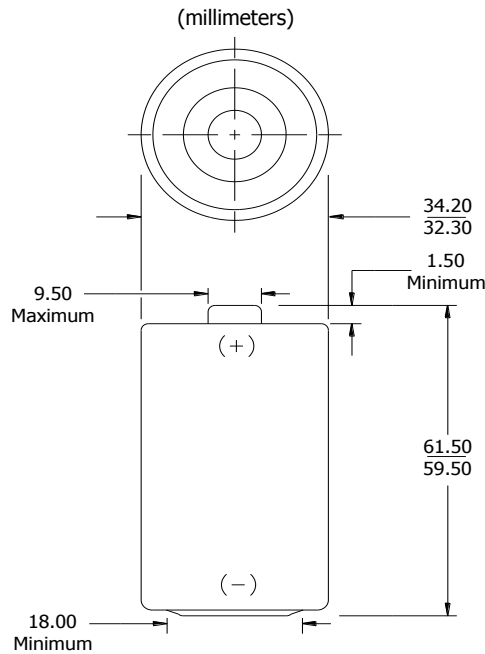

Industry Standard Dimensions



Specifications

<b>Classification:</b>	Alkaline
<b>Chemical System:</b>	Zinc-Manganese Dioxide (Zn/MnO <sub>2</sub> ) No added mercury or cadmium
<b>Designation:</b>	IEC-LR20
<b>Nominal Voltage:</b>	1.5 volts
<b>Operating Temp:</b>	-18°C to 55°C
<b>Typical Weight:</b>	144.0 grams
<b>Typical Volume:</b>	56.0 cubic centimeters
<b>Jacket:</b>	Plastic Label
<b>Shelf Life:</b>	7 years at 21°C
<b>Terminal:</b>	Flat Contact

Performance Comparison

Classic vs. Typical Carbon Zinc (D) at 21°C

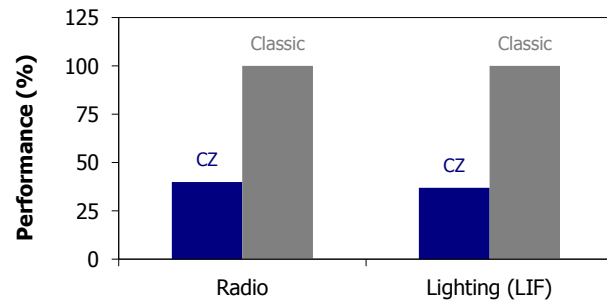

Industry Standard Testing Protocol

Device Selection Guide:

Portable Stereo



Toy



Lighting



Radio



Battery Selection Indicator

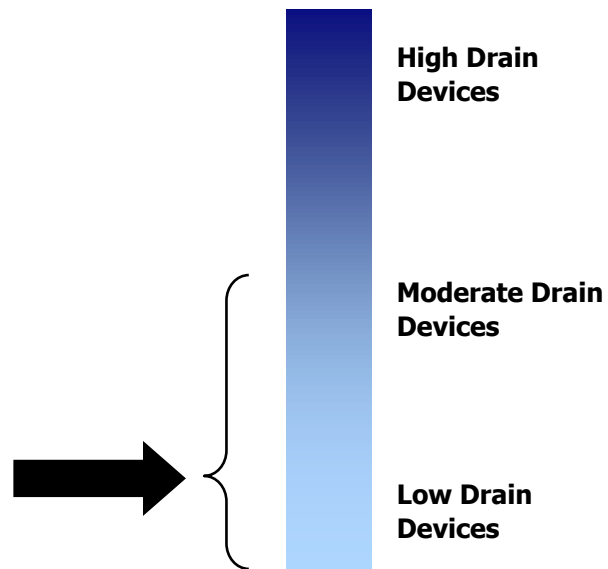

**Important Notice**

This data sheet contains typical information specific to products manufactured at the time of its publication.

©Energizer Holdings, Inc. - Contents herein do not constitute a warranty.